

[CF Series] Taped Radial Lead Forming Equipment



- 適用各種帶裝零件
- 可成型切腳，或可只切腳
- 成型式樣可依客戶要求製作
- 速度可調，全自動供料
- Suitable for various types of radial components.
- Forming tools easy to changeover.
- Easy operation and simple operation.
- Welcome to hand us your forming drawing for best solution.

CF-120 帶裝立式零件成型機 Auto Taped Radial Lead Forming Machine

電壓 Power: 110/220 V AC 50/60Hz
 尺寸 Dimension: 450mm (L), 400mm(Width), 500mm(H)
 淨重 Weight: 24 Kgs
 加工量 Capability: 7,200 pieces /Hour Max.

- 標準配有一組成型模具 和一組切刀。
- 常用 90 度彎腳、SMD 貼片彎腳成型、前後 K...等簡單型狀。
- Equipped one set of forming module and a set of cutter.
- For simple shapes: 90-degree bend, SMD bend, front and back kinks.

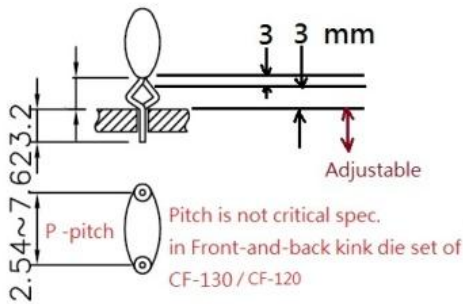
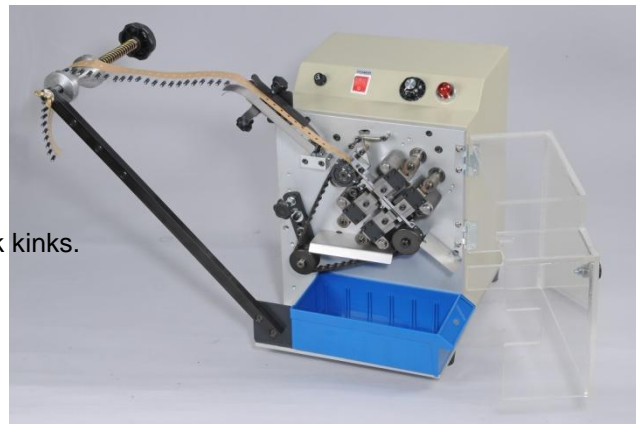

CF-130 帶裝立式零件成型機 Auto Taped Radial Lead Former / Cutters

電壓 Power: 110/220 V AC 50/60Hz
 尺寸 Dimension: 450mm (L), 400mm(W), 500mm(H)
 淨重 Weight: 22 Kgs
 加工量 Capability: 7,200 pieces /Hour Max.

- 標準配有兩組成型模具 和一組切刀。
- 適合繁複成型型狀
- Equipped TWO sets of forming module and a set of cutter.
- For complicated forming shape.
- Die is customized



CF-130

